

MODEL # CRS-2500 STANDARD FEATURES



- 2500 CFM (4340 m3/h) @ 0.5" WC (12mm) external static pressure
- Built-in Economizer Function (requires outdoor sensor)
- High efficiency 1HP direct drive plug fan
- High efficiency secondary axial fan with low noise design
- Separate Primary and Secondary water circuits for optimum efficiency
- Peak power consumption 1550 watts
- 220v 50/60 Hz single phase power
- All stainless steel water reservoirs
- Single point electric connections
- Single point water inlet and drain connections
- 24-volt control panel compatible with any HEAT PUMP type thermostat
- Automatic water quality management system, field adjustable for specific site requirements
- Water limit switches protection for pumps
- Full perimeter base rail with built-in rigging adapters and fork truck slots
- Centralized control board with LED's facilitating component troubleshooting
- Multiple service panels provided for ease of servicing
- Warranty - 5 Year Cabinet; 1 Year Components

	AMERICAN UNITS	INTERNATIONAL UNITS
WEIGHT- NET / OPERATING	500 / 900 Lbs	250 / 425 Kgs
DIMENSIONS - L X W X H	49" x 44" x 46.5"	1442mm x 1117mm x 1182mm

COOLING PERFORMANCE		
Total Equivalent Capacity*	60	MBH
Sensible Capacity	48	MBH
Total Supply Air	2500	CFM

* Based on outdoor ambient condition of 100°F DB and 67°F WB.

SUPPLY AIR PERFORMANCE		
Total Supply Air	2500	CFM
Ext. Static Pressure	0.5	IWG
Blower Speed	1500	RPM
Power Output Req.	0.94	BHP
Motor Rating	1	HP
Power Input Req.	1.65	KW

TOTAL UNIT WEIGHT		
Shipping	600	lbs
Net	500	lbs

ELECTRICAL DATA		
Power Supply	230/1/50-60	V/Ph/Hz
Total Unit Ampacity	10	AMPS
Max. Overcurrent Device	20	AMPS



SPEAKMAN®
Absolutely the best.

CRITICAL DIMENSIONS

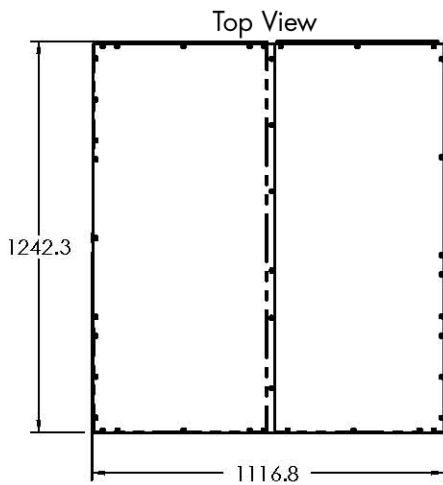
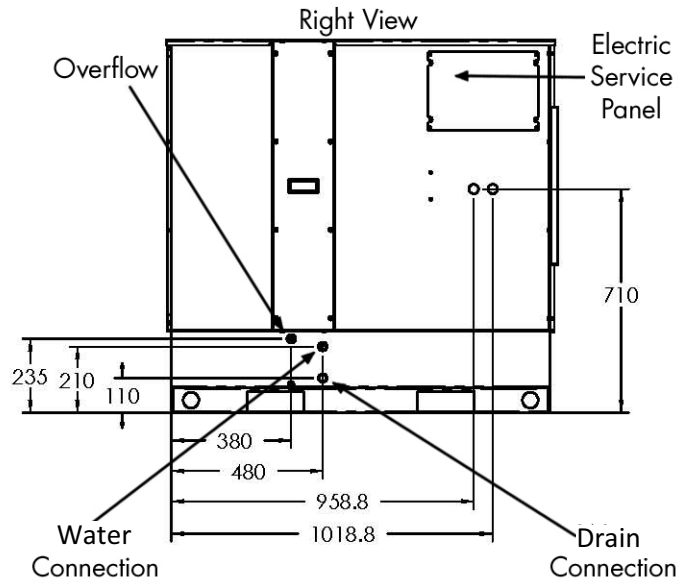
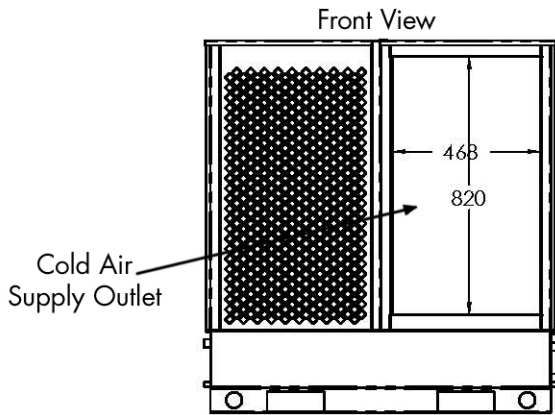
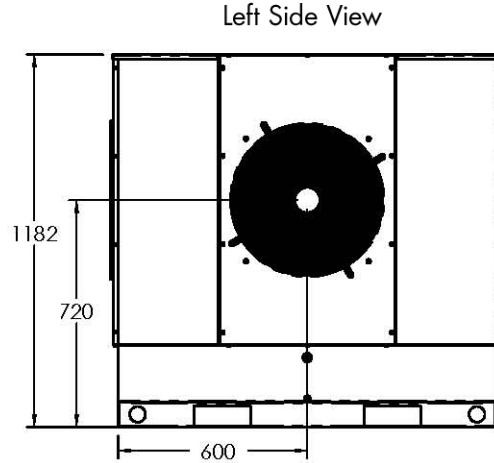
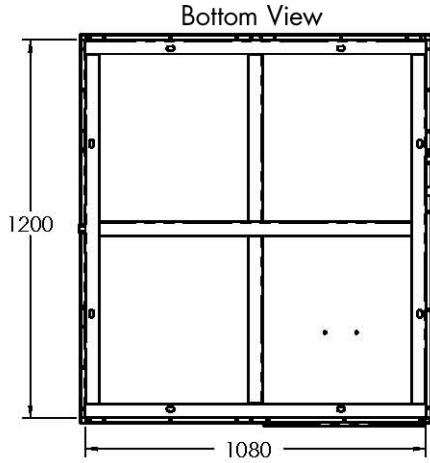

All dimensions are in millimeters.

SPEAKMAN[®]
Absolutely the best.